

A Frequency Synthesizer with Passive Mixer and LC-Tuned BPF for UWB Applications

Tae-won Ahn^{1,3}, Je-cheol Moon², Yong-woo Kim³, and Yong Moon³

¹ School of Electrical Engineering, Dongyang Technical College

62-160 Kochukdong, Kurogu, Seoul, 152-714 Korea

² FCI Inc., Sunnam City, Kyounggido, Korea

³ School of Electronic Engineering, Soongsil University

Sangdo-5-dong, Dongjak-ku, Seoul, 156-734 Korea

E-mail: ¹twahn@dongyang.ac.kr, ²munja@fci.co.kr, ³moony@ssu.ac.kr

Abstract: A fast-hopping frequency synthesizer that reduces complexity and power consumption is presented for MB-OFDM UWB applications. The proposed architecture uses 3960 MHz LC VCO, 528 MHz ring oscillator, passive mixer and LC-tuned Q-enhancement BPF to generate Band Group 1 frequencies. The adjacent channel rejection ratio is less than -40 dBc for 3432 MHz and -44 dBc for 4488 MHz. A fast switching SCL-type MUX is used to produce the required channel output signal and it takes less than 2.2 ns for band switching. The total power consumption is 47.9 mW with a 1.8-V supply.

1. Introduction

Recently, an ultra-wideband (UWB) technology is getting a lot of attentions as a technology for implementation of very high data rate indoor wireless networks. Especially, this technology has an advantage that can solve various problems of 802.11x technology effectively.

Among the different UWB technology options, the MB-OFDM approach has been studied much, which divides the whole frequency band of 3.1~10.6 GHz into 14 sub-bands of 528 MHz each, and classified by 4 frequency band groups. The first band group, which is the lowest part of the spectrum (3168~4752 MHz) is denoted as Band Group 1, is considered as mandatory, and the higher frequency band groups are optional [1]. Therefore, frequency synthesis for band group 1 is essential, and it can be an important issue to optimize frequency synthesizer that support the bands with center carrier frequencies of 3432 MHz, 3960 MHz, and 4488 MHz.

According to the spectrum mask requirements being considered in Japan and Europe, the power emissions without the interference migration technique called detect-and-avoid (DAA) is limited to -70 dBm/MHz in bands of 3432 MHz and 3960 MHz, which is about 30 dB lower than in 4488 MHz band. So, it requires spurious level of less than -30 dBc for the band with center carrier frequency of 4488 MHz to meet the requirement, and considering about 10-dB margin, the adjacent channel rejection ratio should be less than -40 dBc for 4488 MHz carrier signal [2].

Furthermore, MB-OFDM standards require fast switching time (9.47 ns) between different band frequencies within a band, the conventional structure of general frequency synthesizers can not satisfy the required specification [3]. Therefore, some possible ways of performing the frequency synthesis with multiple PLLs and SSB mixers have been studied, where the complexity and power consumption can be increased [4].

In this paper, we suggest a configuration that reduces complexity and power consumption using passive mixer and LC-tuned Q-enhancement BPF in order to implement a frequency synthesizer for MB-OFDM UWB applications.

2. Proposed Architecture

Figure 1 shows the block diagram of the proposed MB-OFDM frequency synthesizer which has two integer-N PLLs to generate both frequencies of 3960MHz and 528MHz independently with the same reference clock of 33 MHz. We use 3960 MHz LC VCO and 528 MHz ring oscillator considering the wide sub-carrier frequency spacing, and apply passive mixer to create Band Group 1 frequencies of 3432 MHz and 4488 MHz. A LC-tuned Q-enhancement BPF selects the desired channel frequency with 1-bit channel selection signal, and poly-phase filter (PPF) generates I/Q signals from the output of BPF and buffer. Finally, a fast switching SCL-type MUX produces the required channel output signal.

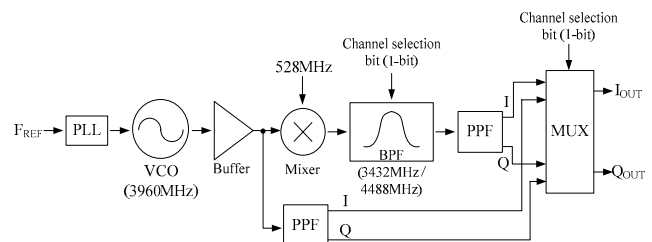

Figure 1. Block diagram of the proposed frequency synthesizer

In this paper, we adopt passive type PPF for low power consumption which is adequate for UWB features, and use a single passive mixer to reduce power consumption while improving the linearity of mixer.

Another possible way to generate the required I/Q channel output signals is to utilize double SSB mixers, but it results in large chip size, and the traditional SSB mixers dissipate much power and usually suffer from spurious spectrum purity [2].

Also, we employ LC-tuned Q-enhancement BPF for high sideband rejection as well as lower power consumption than the previous scheme using multiple SSB mixers. So, the proposed fast-switching frequency synthesizer can reduce power consumption and chip area for MB-OFDM UWB applications.

3. Circuit Design and Simulation

The simplified circuit diagrams of the key blocks for the proposed frequency synthesizer are shown in Figure 2~Figure 3.

3.1 VCO design

We used a cross-coupled LC VCO as shown in Figure 2(a) to generate the signal of 3960 MHz and Figure 2(b) shows the VCO buffer. The designed LC VCO consists of a PMOS negative-Gm core to reduce flicker noise. The tank comprises two 0.97 nH inductors and two accumulation mode MOS varactors are used for frequency tuning. The VCO buffer is designed with source follower amplifier for signal separation.

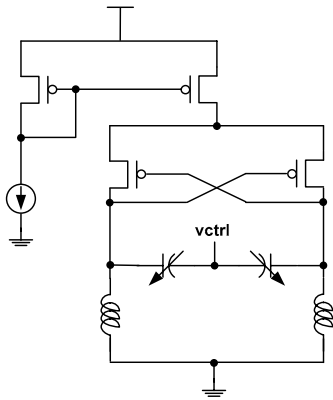

(a) 3960 MHz LC VCO

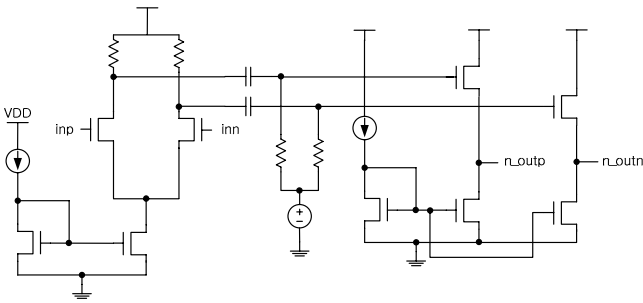

(b) VCO buffer

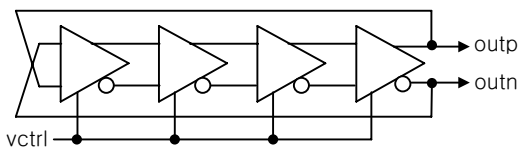

(c) 528 MHz ring oscillator

Figure 2. Simplified circuit diagrams for oscillators

The 528 MHz differential signals are generated from a 4-stage ring oscillator as shown in Figure 2(c). The ring type VCO consumes less current and occupies much smaller, but has poor phase noise comparing with LC type VCO. Because the sub-carrier frequency spacing of OFDM

signals is wide enough (4.125 MHz), the ring VCO can be adopted effectively for MB-OFDM UWB applications [4].

3.2 Mixer and BPF design

Noticeably, the proposed frequency synthesizer adopted a passive mixer as shown in Figure 3(a) mixing the 3960 MHz signal with 512 MHz signal. In Figure 3(a), PLL1 denotes the 3960 MHz output signal from a LC VCO type PLL and PLL2 denotes the 528 MHz output signal from a ring VCO type PLL. Mixing with passive mixer has advantages of higher linearity and lower power consumption than mixing with active mixer. However, it is hard to suppress the sideband rejection performance with passive mixer as itself because perfect matching is hard to be implemented due to the process variation. Adjacent channel rejection ratio using passive mixer can be compensated with LC-tuned Q-enhancement BPF as shown in Figure 3(b).

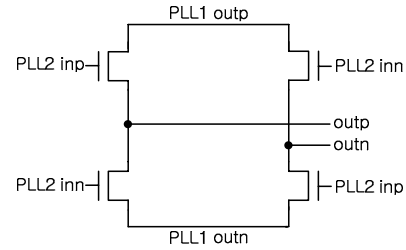

(a) Passive mixer

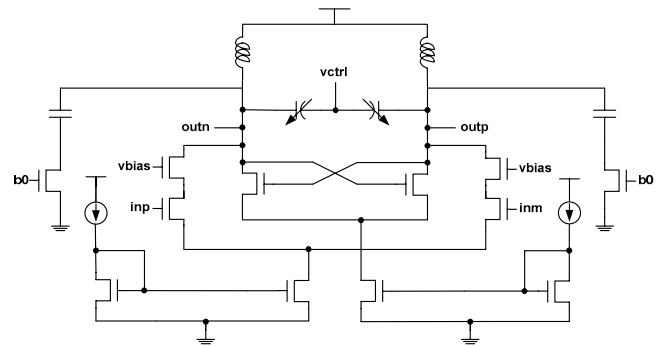

(b) LC-tuned Q-enhancement BPF

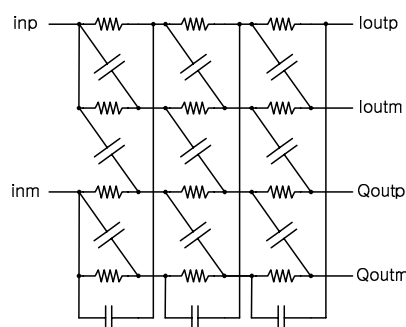

(c) Poly-phase filter

Figure 3. Simplified circuit diagrams for mixer, BPF, and poly-phase filter

The center frequency and the transconductance of the cross-coupled pair of LC-tuned Q-enhancement BPF is determined respectively by the following equation:

$$F_{center} = \frac{1}{2\pi\sqrt{LC}}, \quad G_m \approx \frac{1}{Q^2 \cdot R_s} \quad (1)$$

Q is the quality factor and R_s is the series resistance of the inductor. Actually, the transconductance is set a little bit smaller to avoid the BPF from oscillation. The cascade devices in Figure 3(b) increase the impedance seen by the LC tank so as to decrease the transconductance of the cross-coupled pair and reduce the power consumption. LC-tuned Q-enhancement BPF has the advantage of high filtering effect with a single BPF by LC tank type, but current source and LC-tank structure consume more power than passive BPF. However, using a single BPF structure has an advantage over multiplex BPF or multiple SSB-mixer structure in terms of effective frequency synthesizer implementation [5].

The QPSK modulation scheme of MB-OFDM UWB systems requires quadrature signals from the output of frequency synthesizer. We utilize poly-phase filter as shown in Figure 3(c) in order to generate quadrature signals as well as remove the phase imbalance derived from the VCO output signals and BPF output signals with less power consumption.

3.3 Frequency synthesis and spurious levels

Figure 4 shows the Spectre simulation results of the frequency spectrum of the passive mixer output signals. It shows the generation of 3432 MHz and 4488 MHz carrier output signals by mixing 3960 MHz and 528 MHz oscillation signals.

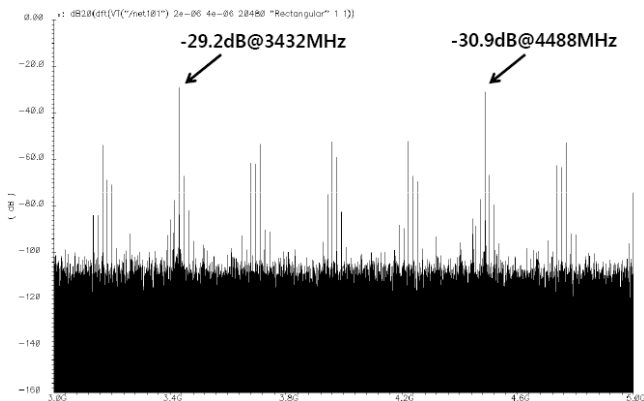

Figure 4. Frequency synthesis simulation results

Figure 5 shows the spurious level simulation results for the 3 whole sub-bands. The output spectrum when generating 3960 MHz carrier signal directly from the LC VCO is shown in Figure 5(a). The output spectrums when generating 3432 MHz and 4488 MHz carrier signal are shown in Figure 5(b) and Figure 5(c) respectively

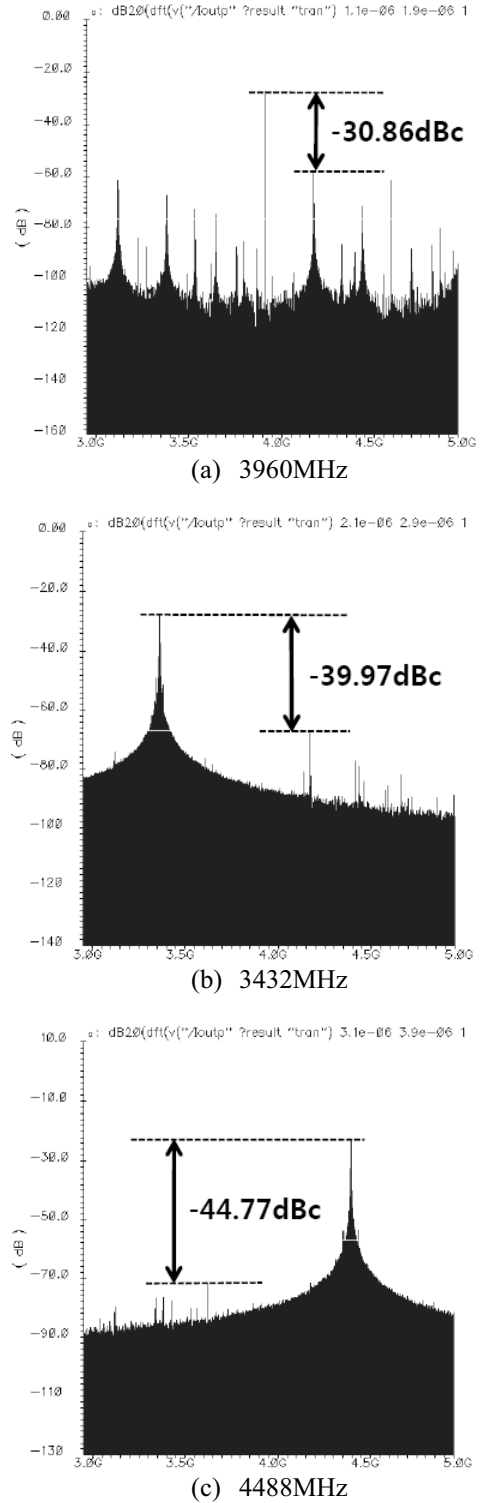
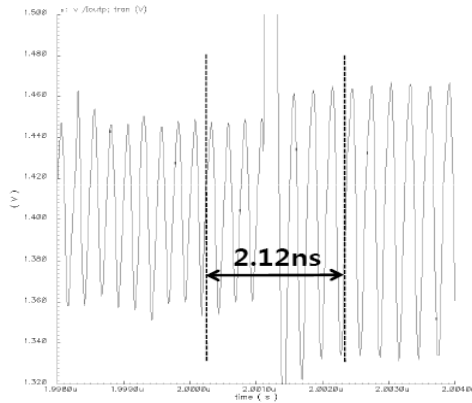

Figure 5. Spurious level simulation results

The adjacent channel rejection ratio of the designed MB-OFDM UWB frequency synthesizer provides less than -30 dBc for 3960 MHz, -40 dBc for 3432 MHz and -44 dBc for 4488 MHz from the simulation as shown in Figure 5(a)~(c). Considering that the spectrum mask spurious level of the band with center carrier frequency of 4488 MHz should be less than -40 dBc, Figure 5(c) shows that the simulation results satisfy the adjacent channel rejection requirements.

3.4 Frequency switching characteristics

Another importance specification for MB-OFDM UWB systems is the settling time for frequency hopping, which must be within 9.47 ns. Figure 6(a) shows the frequency switching simulation results when the output carrier frequency changes from 3960 MHz band to 3432 MHz band, and Figure 6(b) shows the simulation results when the frequency changes from 3432 MHz band to 4488 MHz band, which are well below 9.47 ns.



(a) 3960MHz → 3432MHz

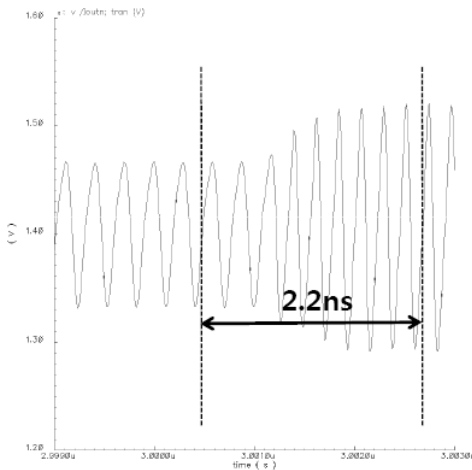

(b) 3432MHz → 4488MHz

Figure 6. Frequency switching simulation results

The proposed MB-OFDM UWB frequency synthesizer has been designed in a 0.18- μm CMOS process and occupies less area than the conventional UWB frequency synthesizer with SSB mixer configuration. The power dissipation is 47.9 mW from a 1.8-V supply. The performance of the designed frequency synthesizer is summarized in Table 1.

Table 1. Performance Summary

Process	0.18- μm CMOS
Power supply	1.8-V
Power consumption	47.9 mW
Output frequency	3432, 3960, 4488 MHz
Frequency hopping time	< 2.2ns
Sideband suppression	< -30 dBc for 3960 MHz < -40 dBc for 3432 MHz < -44 dBc for 4488 MHz

4. Conclusion

In this paper, a fast-hopping frequency synthesizer for MB-OFDM UWB applications is presented. The proposed architecture uses 3960 MHz LC VCO, 528 MHz ring oscillator, passive mixer and LC-tuned Q-enhancement BPF to generate Band Group 1 frequencies. The total power consumption is 47.9 mW with a 1.8-V supply and the adjacent channel rejection ratio is less than -40 dBc for 3432 MHz and -44 dBc for 4488 MHz. The suggested architecture reduces complexity and power consumption and contributes to both low cost and low power UWB applications.

Acknowledgment

This work was sponsored by SoC Industry Promotion Center, Human Resource Development Project for IT SoC Architect. CAD tools were supported by IDEC.

References

- [1] IEEE P802.15-03/268r0-TG3a.2003.
- [2] Takashi Tokairin et al., "A 0.18- μm CMOS Low-spurious Local Signal Generator for MB-OFDM UWB Radio," pp. 215-218, 2007 IEEE RFIC Symposium.
- [3] Chinmaya Mishra et al., "Frequency Planning and Synthesizer Architectures for Multiband OFDM UWB Radios," IEEE Trans. Microwave Theory and Techniques, Vol. 53, No. 12, pp. 3744-3756, Dec. 2005.
- [4] Jung-Eun Lee et al., "A Frequency Synthesizer for UWB Transceiver in 0.13 μm CMOS Technology," pp. 294-297, SiRF 2006.
- [5] Che-Fu Ling et al., "A Fast-Switching Frequency Synthesizer for UWB Applications," pp. 197-200, Asian Solid-State Circuits Conference, 2005.